

Turreteer

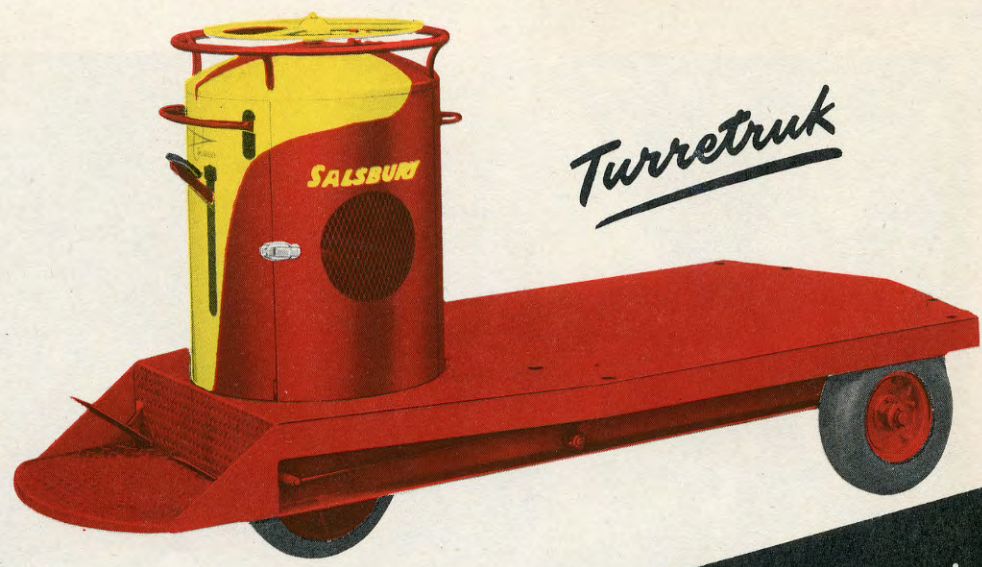

Turretug



Turretruk

**SALSBURY**

**TURRET  
TRUCKS**

An innovation . . . . .  
in mechanized materials handling equipment,  
emphasizing speed, safety and efficiency.

# Easily Negotiates Narrow Aisles, Tight Corners,

Loads too big for manual movement and too light for heavy equipment constitute a majority of all traffic in any materials handling system. The speed and economy with which *in-between handlings* are picked up, transported and spotted largely determine the overall efficiency of the operation. Salsbury Turret Trucks are specifically designed for this class of work.

These trucks team nicely with existing systems, serve in the elimination of waste motion and speed up flow of materials. Less manpower is required and the truck handler's work burden is lightened—*he rides the load*.

The power plant and the drive wheel are built as a single rotatable unit. Reversing gear mechanism is eliminated as direction of travel is controlled by rotation of the complete Turret Power Unit. Fast reversing is accomplished while drive unit is in motion.

A smooth flow of power—as required—is provided by the Salsbury Model 600 Power Package: a 6 hp Salsbury four cycle, single cylinder, air-cooled engine, equipped with a Salsbury Automatic Transmission and a Salsbury Automatic

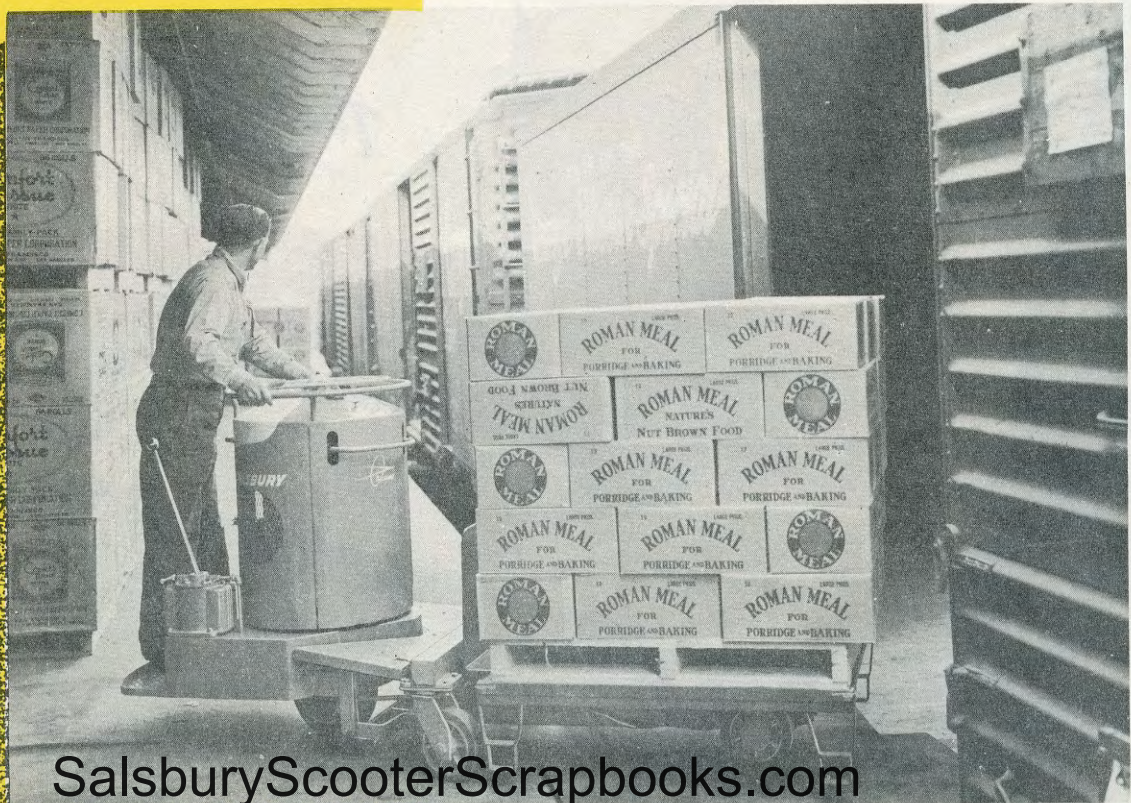

[SalsburyScooterScrapbooks.com](http://SalsburyScooterScrapbooks.com)

**SALSBURY MOTORS, INC.**

# Sharp Changes in Grade Levels and Steep Ramps

Clutch. Ramps are more easily negotiated with this Automatic Drive as there are no gears to shift.

Unsurpassed load stability is inherent in the Salsbury Turreteer due to the unique type of articulation which is exclusive with this equipment. Wide tread, four point load suspension is provided at all times, thus insuring smooth, safe handlings.

The short turning radius (28") of the Salsbury Turretug widens the use of tractors for operating in cramped quarters. Two or more trailers are easily handled.

Rough terrain presents no problem to the Salsbury Turretuk. Ample cargo deck is available. This truck possesses a high degree of maneuverability with speeds to 8 mph.

Salsbury Turret Trucks are the result of exhaustive studies in the horizontal movement of materials. An examination of the detailed specifications will show just how many practical features of construction, operation and ease of maintenance have been incorporated to speed up the job and increase the loads handled per man-hour, thereby reducing to a minimum production and warehousing transportation costs.

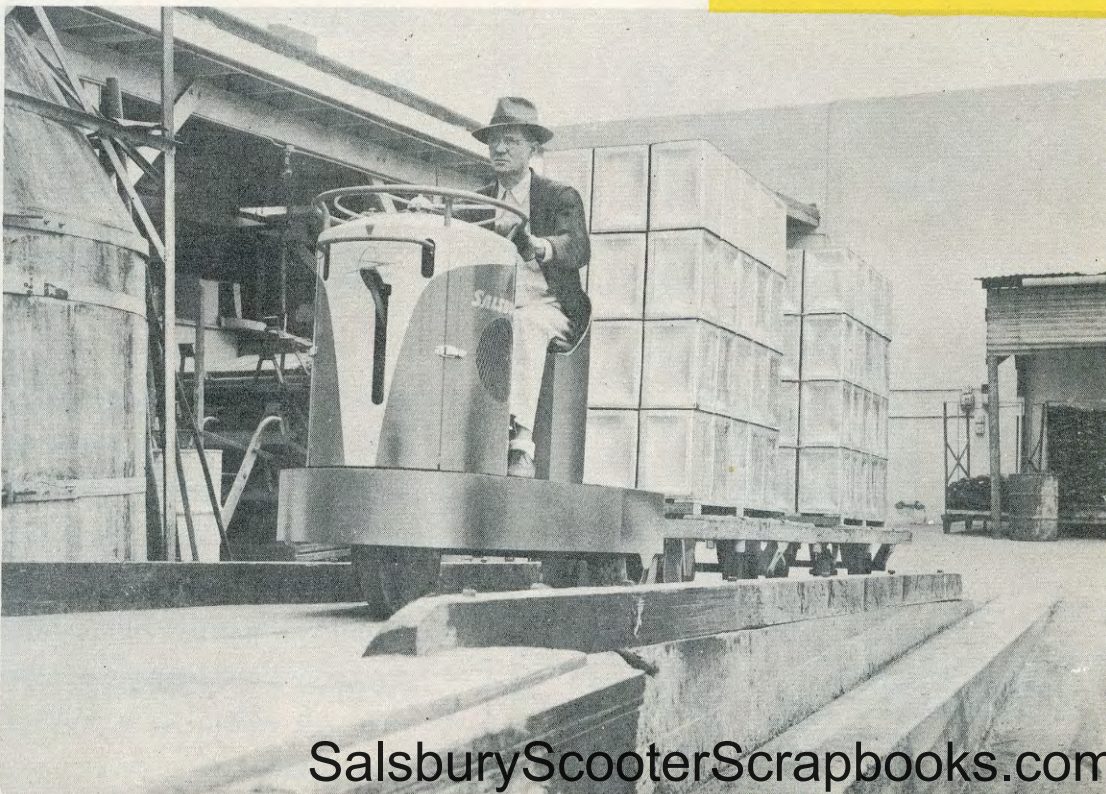
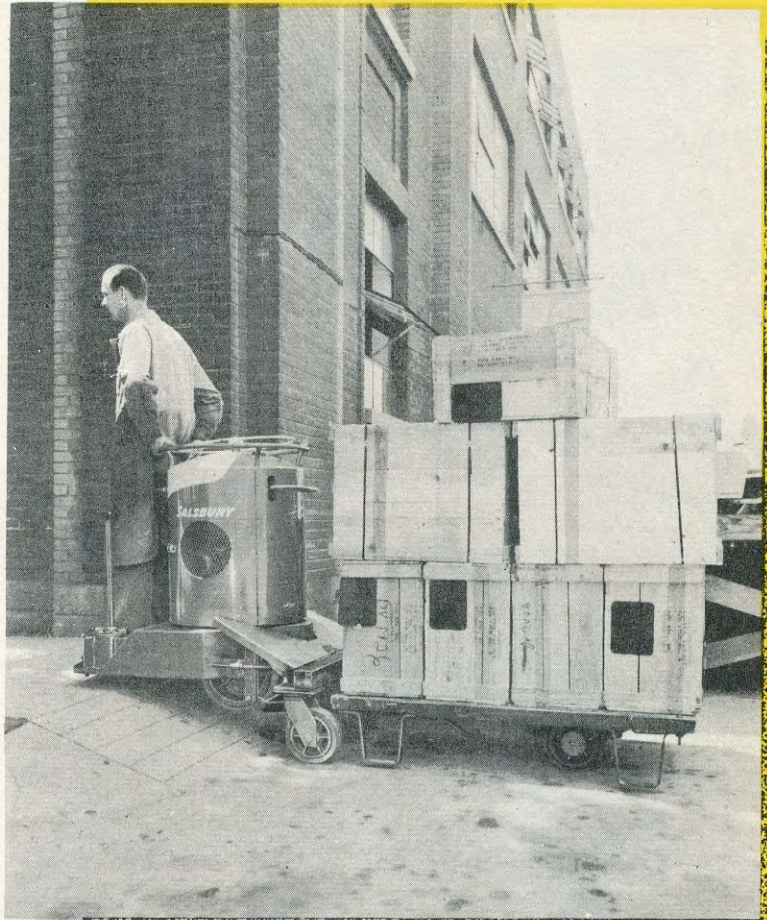

[SalsburyScooterScrapbooks.com](http://SalsburyScooterScrapbooks.com)

**POMONA, CALIFORNIA**

# A New High

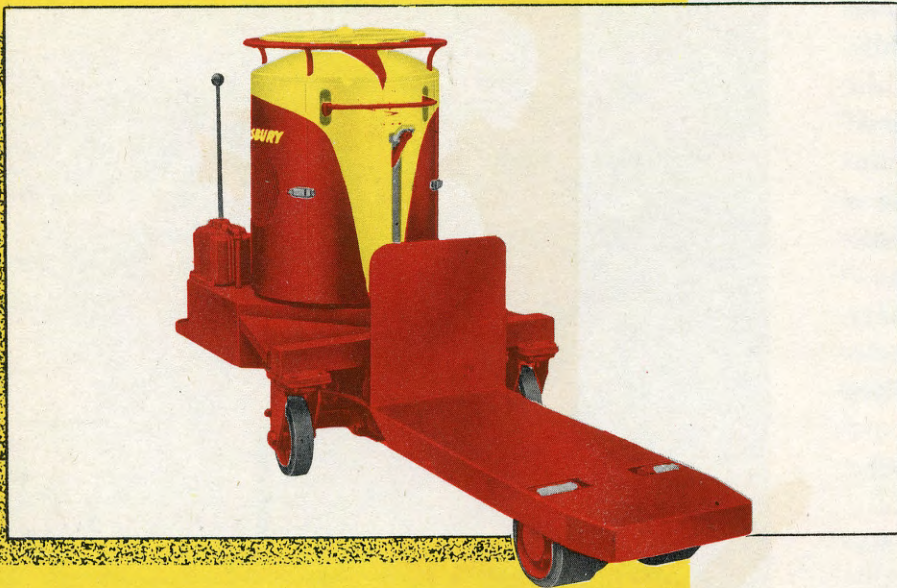

## **SALSBURY** **TURRETEER**

A platform lift truck with four widely spaced wheels under the load at all times. Fully articulated, it easily negotiates sharp changes in grade levels, uneven ground and floor surfaces. Equipped with heavy duty 3½" hydraulic lift. Models to handle any standard skid. Travel speeds to 8 mph.

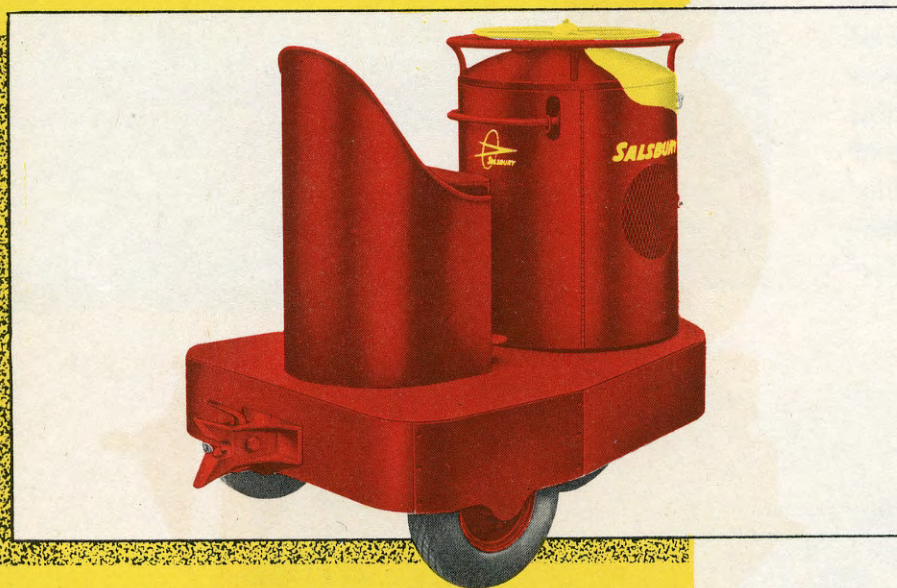

## **SALSBURY** **TURRETUG**

A 28" turning radius materials handling tractor for trailer systems. Trains of two or more loaded trailers easily handled. Can be furnished with any standard type coupler. Deep, innerspring cushion seat and comfortable back rest.



## **SALSBURY** **TURRETRUK**

A bulk cargo handling truck with a large deck. Easily manipulated around sharp corners and through narrow aisles. Ideal for inter-factory transportation of work-in-process, in railroad stations and on airports for express and luggage transportation. All wheels have positive ac-

# in Maneuverability

## COMPLETELY *AUTOMATIC* POWER UNIT

Salsbury Turret Trucks are the most completely automatic materials handling equipment ever built. All models are powered by the same unique Turret Power Unit. Directly connected to the drive wheel and rotating with it according to change in direction is the Salsbury single cylinder, 4 cycle, air-cooled engine, which develops 6 hp at 2650 rpm.

This engine was especially designed for vehicular application and features "straight shot carburetion"—a horizontal carburetor with short, straight intake manifold, mounted on an inclined cylinder—and pressure lubrication by means of a gear type oil pump, mounted within the crankcase, force feeding engine bearings through drilled passages.

Between the engine and the double chain reduction drive is the Salsbury automatic clutch and automatic transmission. Necessity for clutch lever, gear box and gear shift lever is eliminated. Clutch automatically takes hold with smooth, gentle, yet positive action as engine speed is increased, disengages automatically upon deceleration. Transmission automatically shifts from "low" to "high", according to road speed and load requirement. Ratio in "low"—60 to 1; in "high"—12 to 1; ratios in between—ininitely variable.

Extremely wide hinged doors on both sides of the Turret Power Unit makes all parts easily accessible for adjustment or tune-ups. The complete power unit may be quickly removed. A 3½ gallon gasoline tank—sufficient for 10 hours continuous operation—is mounted in the dome. Crankcase oil capacity is 2 quarts.

Other highlights in the design and construction of the Salsbury Turret Power Unit include:

### **Ignition**

Externally mounted magneto.

### **Governor**

Flyball type—accessibly mounted on magneto gear.

### **Starter**

Foot Pedal.

### **Muffler**

Automotive Type.

### **Primary Drive**

Fully enclosed triple strand chain running in oil.

### **Final Drive**

Heavy Duty Chain.

### **Bearings**

Oil Sealed Ball Type.

### **Drive Wheel**

16" x 4"—Industrial Press-on Rubber Tire. Tapered roller bearings.

### **Brake**

Internal Expanding (two shoe type) with 7" drum. Hand operated.

CUTAWAY VIEW  
OF  
SALSBU  
RY  
AUTOMATIC  
CLUTCH AND  
TRANSMISSION

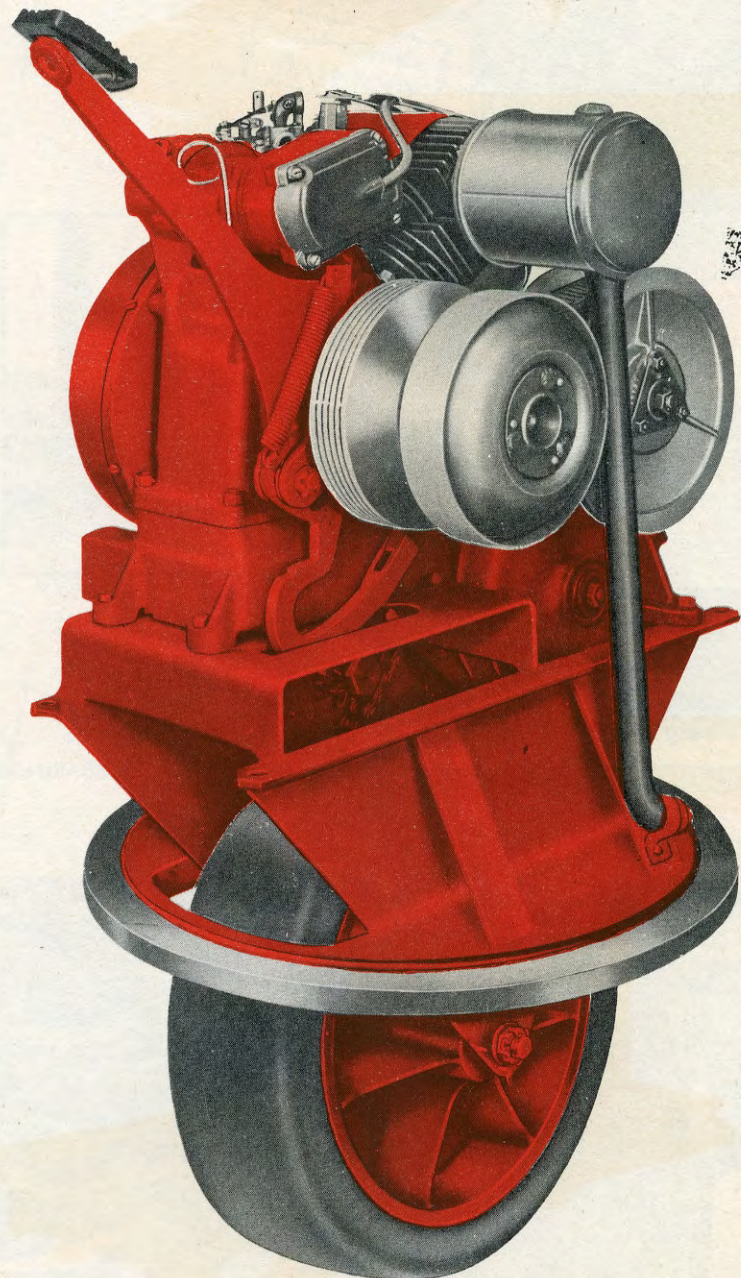
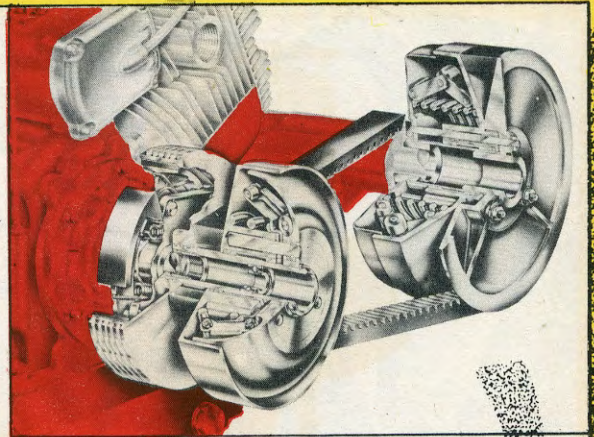

# Simply Controlled, Husky and Unusually Stable

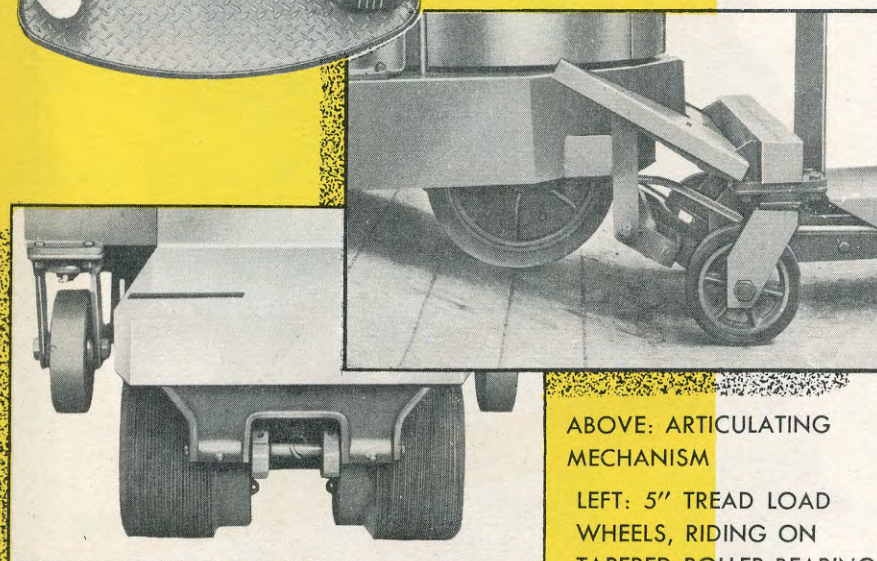
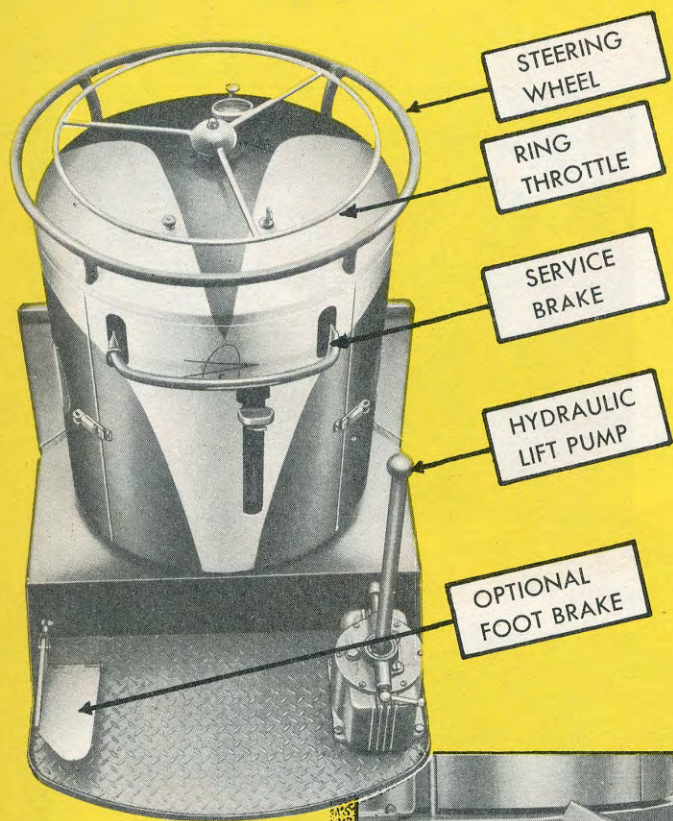

ABOVE: ARTICULATING MECHANISM

LEFT: 5" TREAD LOAD WHEELS, RIDING ON TAPERED ROLLER BEARINGS

Simple, rugged and compact, Salsbury Turret Trucks are designed to give years of dependable service.

Only two controls are required — throttle and brake. Auxiliary load wheel brakes are standard equipment on the Turretug and Turretruk—optional on the Turreteer in the 9" and 11" sizes.

The sturdy construction of all Salsbury Turret Trucks is illustrated below in the undercarriage view of the Turreteer. Note these important features: Rugged, arc-welded, unit frame construction; single piece heavy-duty steel plate platform deck; specially designed heavy duty ram with over-size cylinder; pressure grease fittings to all moving parts; large diameter turret turntable for easy steering; easily demountable drive wheel; unique and exclusive articulation with widely spaced caster wheels for maximum load stability.

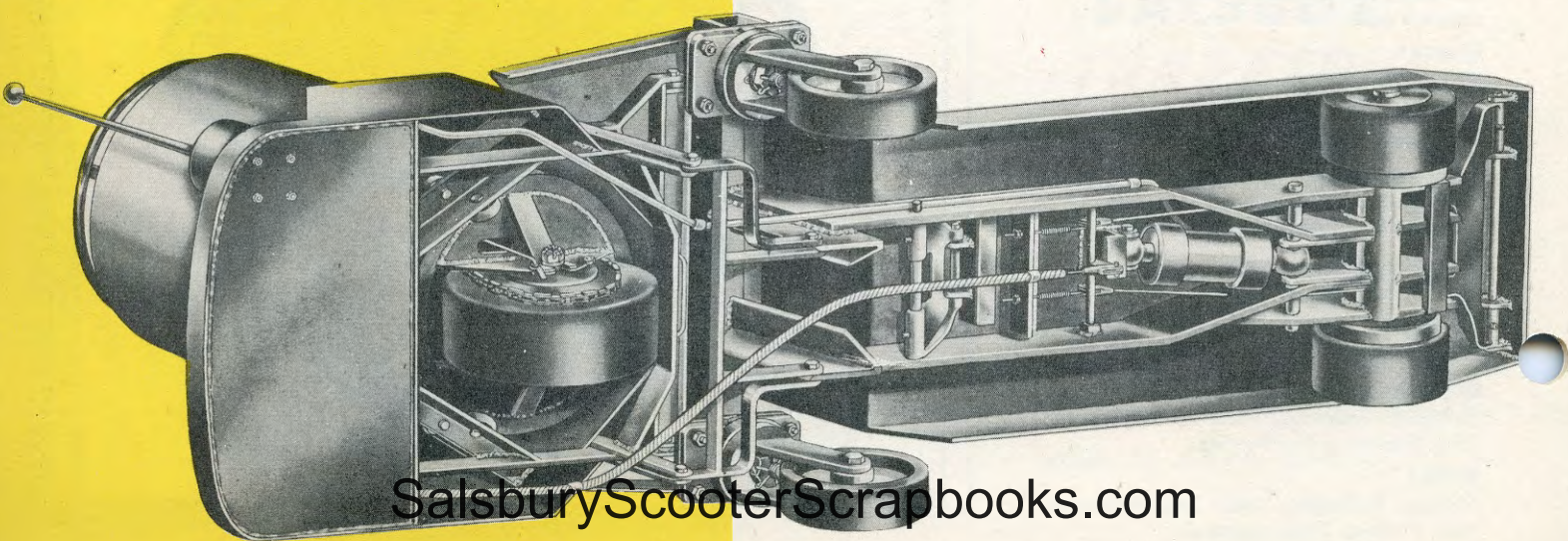

# DIMENSIONS AND SPECIFICATIONS

## TURRETEER—Platform Lift Type

### Capacity . . .

4000 lbs.

### Speed . . .

Up to 8 mph.

### Turning Radius . . .

42" Platform—56"

48" Platform—62"

60" Platform—74"

72" Platform—86"

### Platform Lift . . .

3½"

### Hydraulic System . . .

Heavy Duty Blackhawk Pump located on operator's platform. Specially designed heavy duty ram.

### Load Wheels . . .

Rear—6" or 9" dia. x 5" tread

Caster—9" dia. x 2½" tread.

### Load Distribution . . .

Rear Wheels 80%.

Caster Wheels 20%.

### Weight . . .

Approx. 1000 lbs.

## TURETUG—Tractor Type

### Drawbar Pull . . .

Normal—350 lbs.

Maximum—500 lbs.

### Speed . . .

Up to 8 mph.

### Turning Radius . . .

28"

### Trail Wheels . . .

4.00 x 8, 4-ply Tires.

### Couplers . . .

All Standard Types.

### Driver's Seat . . .

Automotive Type Innerspring Cushion and padded backrest.

### Weight . . .

Approx. 800\* lbs.

\*Counter weights for maximum drawbar pull are available in 200, 250 and 400 lb. sizes.

## TURRETRUK—Cargo Type

### Capacity . . .

2000 lbs.

### Speed . . . . .

Up to 8 mph.

### Turning Radius . . .

58"

### Trail Wheels . . .

4.00 x 8, 4-ply tires.

### Coupler . . .

Towing eye only.

### Weight . . .

Approx. 900 lbs.

NOTE: Load and Trail Wheels on all Salsbury Turret Trucks are equipped with tapered roller bearings.

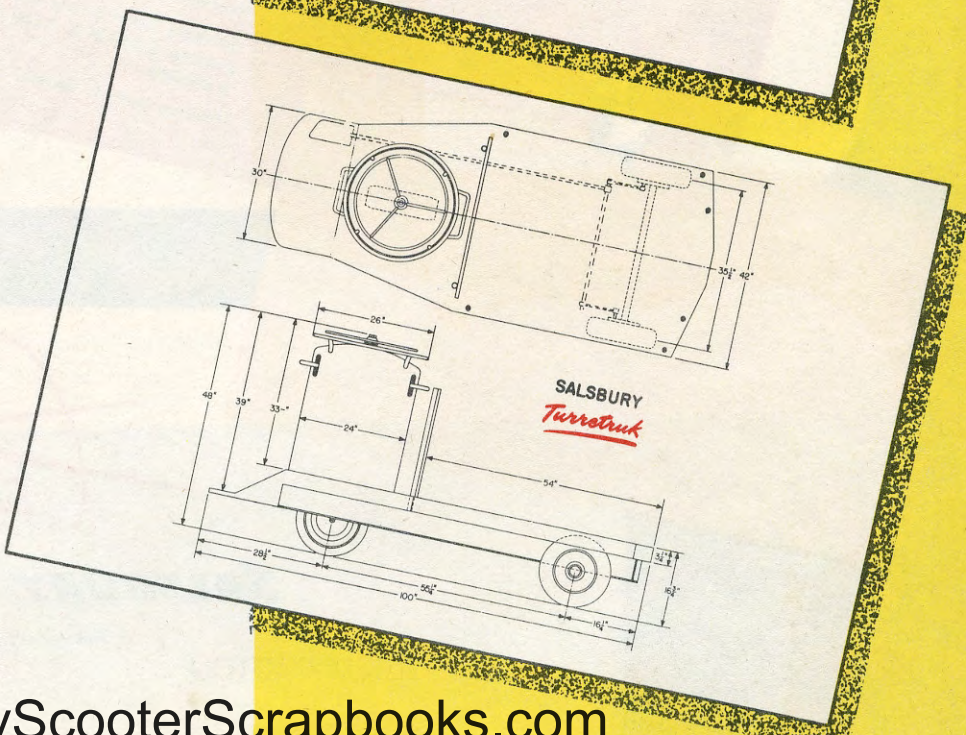
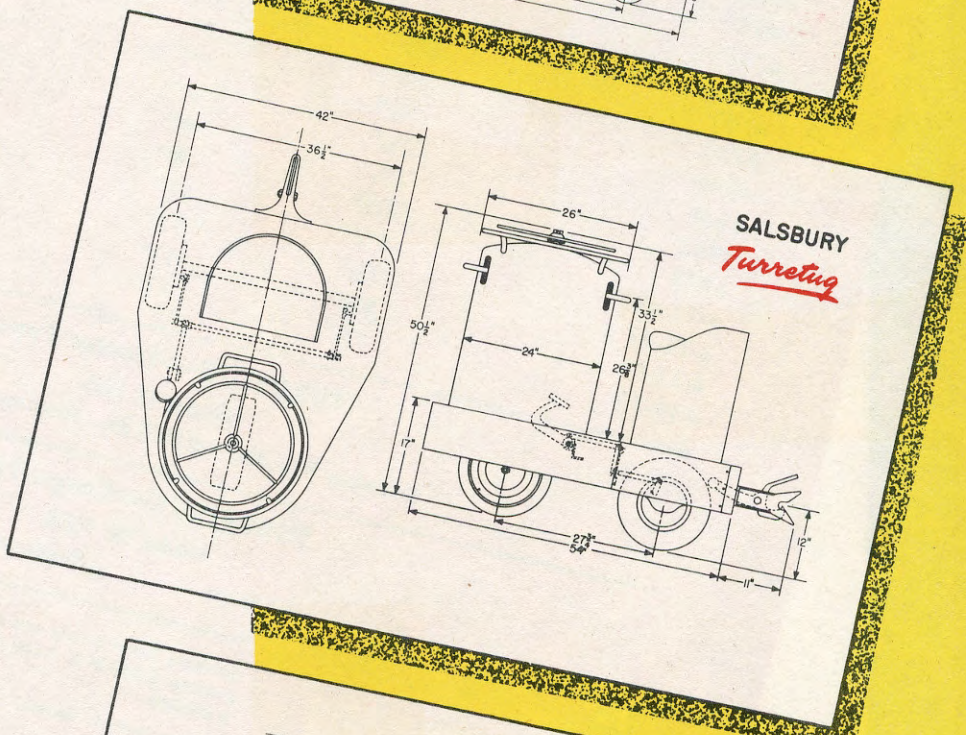
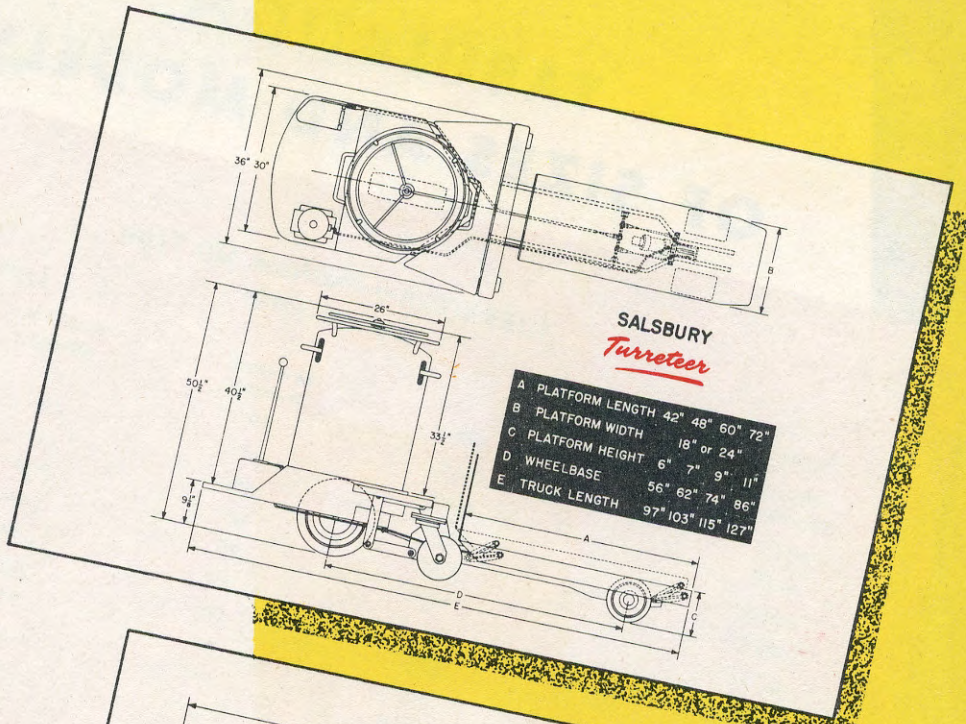

# TABULATION OF SIZES AND MODELS

## TURRETEER—Platform Lift Type Capacity 4000#

### Type TLN—18" wide

Model Number
4642
4648
4660
4672
4742
4748
4760
4772
4942
4948
4960
4972
4-11-42
4-11-48
4-11-60
4-11-72

Lift
3½"
3½"
3½"
3½"
3½"
3½"
3½"
3½"
3½"
3½"
3½"
3½"
3½"
3½"
3½"
3½"
3½"
3½"
3½"
3½"
3½"
3½"
3½"
3½"

Lowered Height
6"
6"
6"
7"
7"
7"
7"
7"
9"
9"
9"
9"
9"
9"
9"
11"
11"
11"
11"

### Type TLW—24" wide

Platform Length	Clearance
42"	2"
48"	2"
60"	2"
72"	2"
42"	2"
48"	2"
60"	2"
72"	4"
42"	4"
48"	4"
60"	4"
72"	4"
42"	4"
48"	4"
60"	4"
72"	4"
42"	4"
48"	4"
60"	4"
72"	4"

## TURRETUG—Tractor Type Model TT-500

Drawbar Pull: Normal 350 lbs., Maximum 500 lbs.

## TURRETRUK—Cargo Type Model TR-2000

Capacity: 2000 lbs.

Platform Size 42" x 54"

Salsbury Turret Trucks are manufactured and sold under the following U. S. Patents: 2,230,293, 2,260,795, 2,260,796, 2,260,797, 2,260,798, 2,275,046, 2,370,866.  
Foreign patents issued. Other patents pending.



**SALSBURY MOTORS, INC.**

A Subsidiary of Northrop Aircraft, Inc.

1201 LEXINGTON

POMONA, CALIFORNIA

[SalsburyScooterScrapbooks.com](http://SalsburyScooterScrapbooks.com)