

SALSBURY

Automatic DRIVE

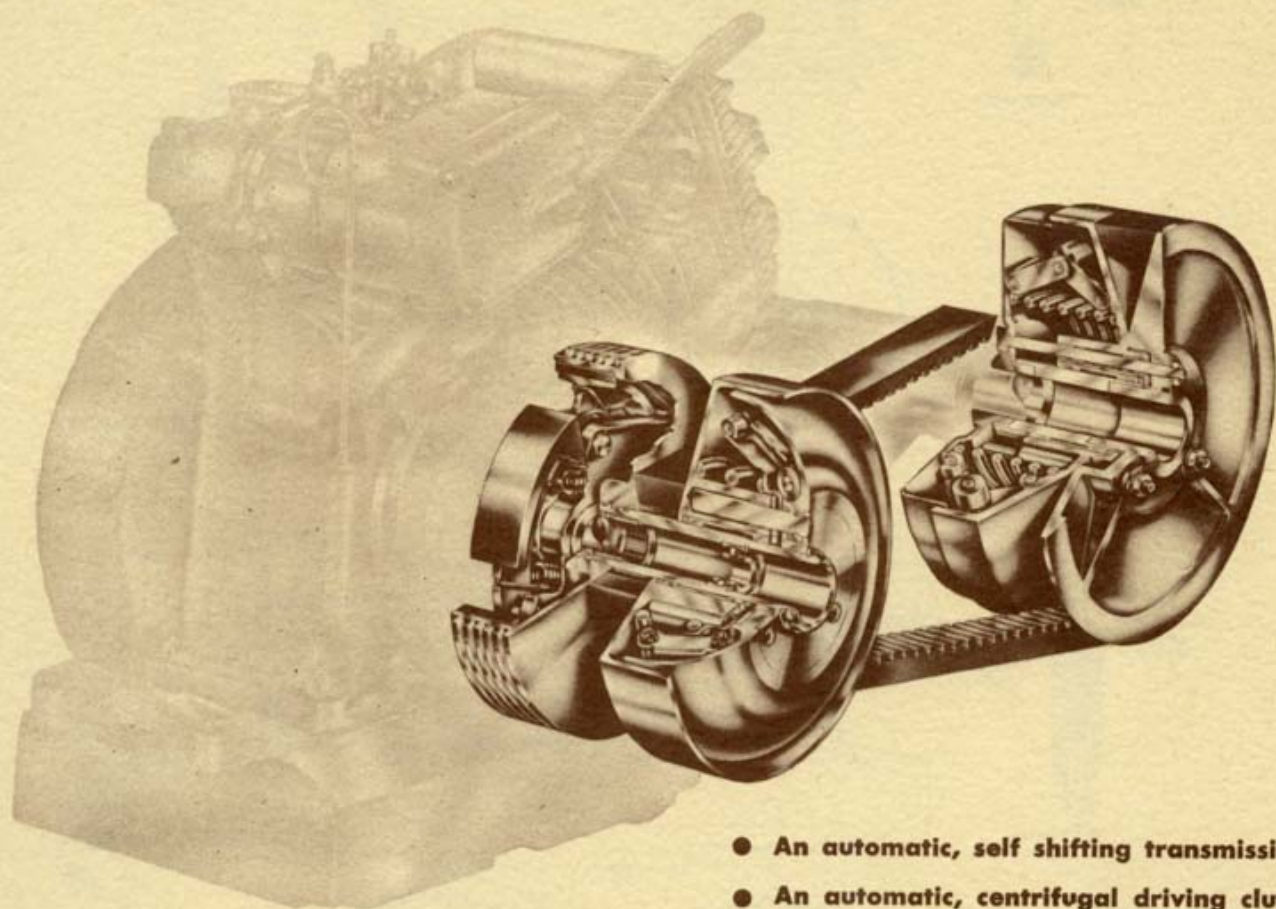

- An automatic, self shifting transmission.
- An automatic, centrifugal driving clutch.
- For gasoline engines in the 1 to 10 hp range.

The Salsbury Automatic Drive achieves true torque conversion through automatic self shifting according to the load and the speed of the driven unit. Clutch automatically engages smoothly and positively, at pre-determined engine speed and disengages upon deceleration below that speed. An infinitely variable range of speeds within its high and low ratio limits are obtained without any gear shifting. Drive may

be coupled directly, geared, chained or belt driven according to the unit or application requirement. On the average gasoline engine, speeds are developed from the output shaft varying from 500 rpm "in low" with full torque to 5,000 rpm "in high". Normal overall range of ratios is from 4 to 1. Final reductions of from 50 to 1 "in high" to 200 to 1 "in low" are available.

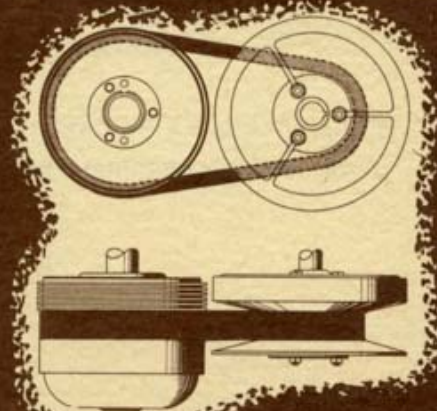
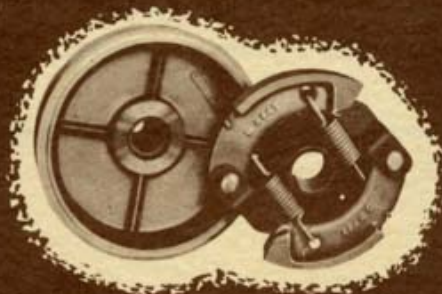
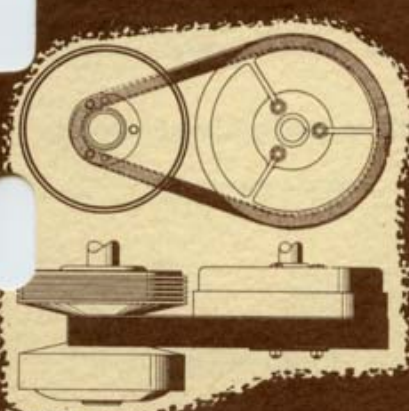

Dimension Charts of
SALSBURY Automatic DRIVES

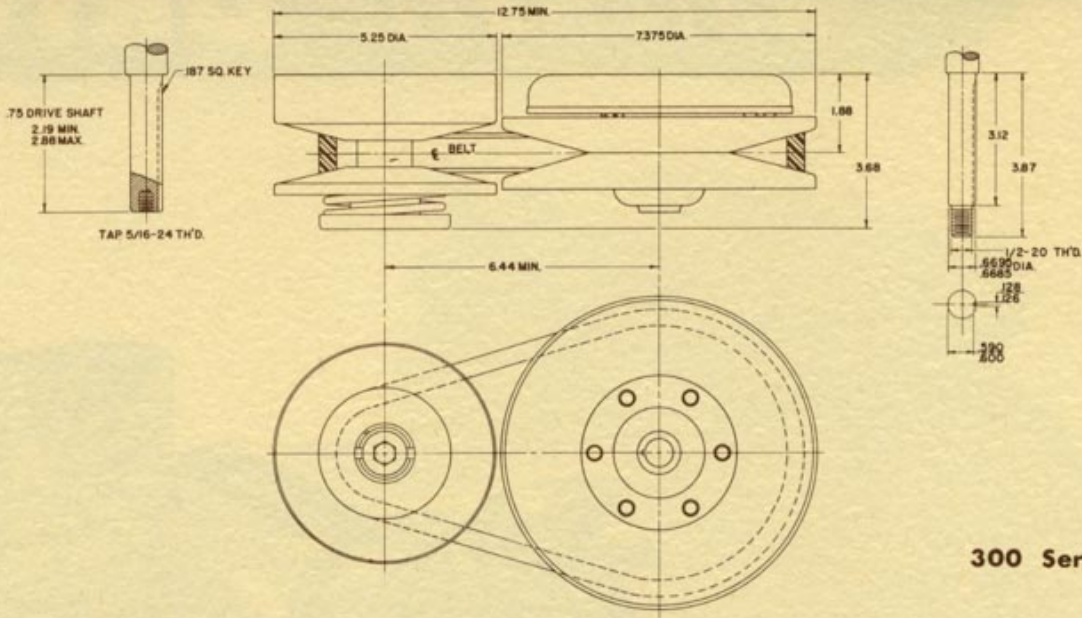

300 Series

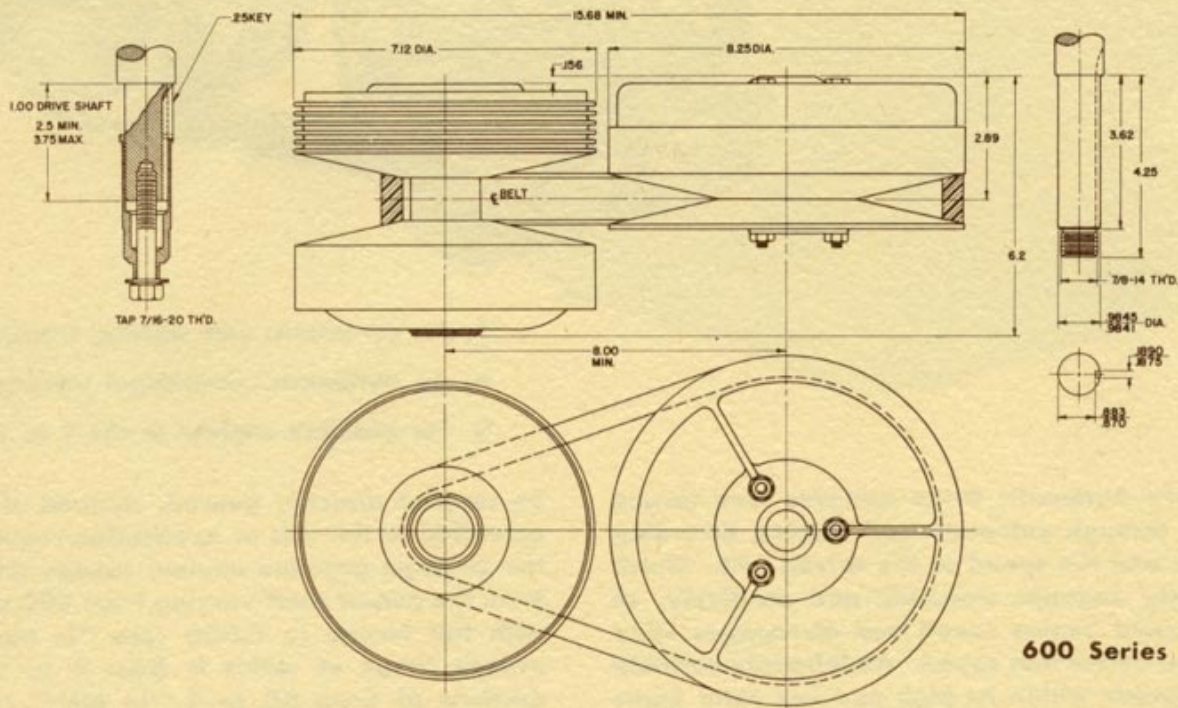

600 Series

Salsbury Automatic Transmissions and Clutches are manufactured under U. S. Patents 2230293, 2260796, 2260797, 2260798, 2275046, and 2286461.

Foreign Patents Issued
 Other Patents pending.

YOUR INQUIRY INVITED: Our engineers will be pleased to furnish full specifications, performance curves, prices and recommendations to fit your needs.

RECEIVED

MAR 5 1956

F. K. WOLL

The Salsbury "600" Series Automatic Clutch
— for —
Gasoline Engines and Electric Motors

SALSBURY
AUTOMATIC CLUTCHES

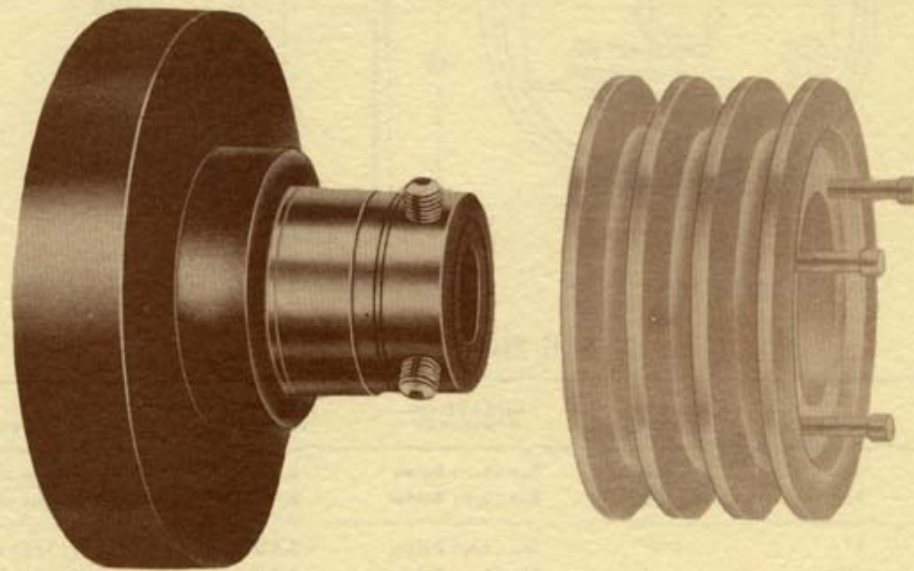

"600"
SERIES

The Salsbury "600" Series Automatic Clutch is designed to meet the need for a compact, rugged, light weight, self contained clutch to provide dependable, trouble-free operation under the most gruelling conditions. It is highly recommended by manufacturers of a wide variety of equipment and is approved by leading gasoline engine manufacturers.

FOR GASOLINE ENGINES from 3 to 10 H.P. with 1" or 1½" diameter shaft extensions. It automatically picks up the load smoothly, but positively, when engine is accelerated. Load free starting and idling are provided.

FOR ELECTRIC MOTORS 2 to 5 H.P., 1750 rpm, it permits motor to operate at an efficient speed while accelerating the load. It reduces starting current demand and provides overload protection.

Design of the "600" Series may be modified for special requirements where ever quanti-

OUTSTANDING FEATURES

- RUGGED TWO-SHOE DESIGN
- SIMPLE CONSTRUCTION — FEW PARTS
- LIGHT WEIGHT, BUT STURDY
- MINIMUM SERVICE REQUIRED
- MORE THAN 24 SQUARE INCHES OF HEAVY DUTY LINING, EASILY REPLACEABLE
- BROAD SELECTION OF DETACHABLE SHEAVES OR SPROCKETS
- INSTALLATION WITHOUT ALTERING PRESENT SHAFT EXTENSION
- LOW COST

ties warrant. Other model clutches and Salsbury Automatic Variable Speed Transmissions also are available.

Feel free to submit your power transmission problems — no obligation.

— DISTRIBUTED BY —

RECEIVED

MAR 5 1956

F. K. WOLL

POWER TRANSMISSION DIVISION

1161 EAST FLORENCE • LOS ANGELES 1, CALIFORNIA • PHONE JEFFERSON 4151

SALSBURY
CORPORATION

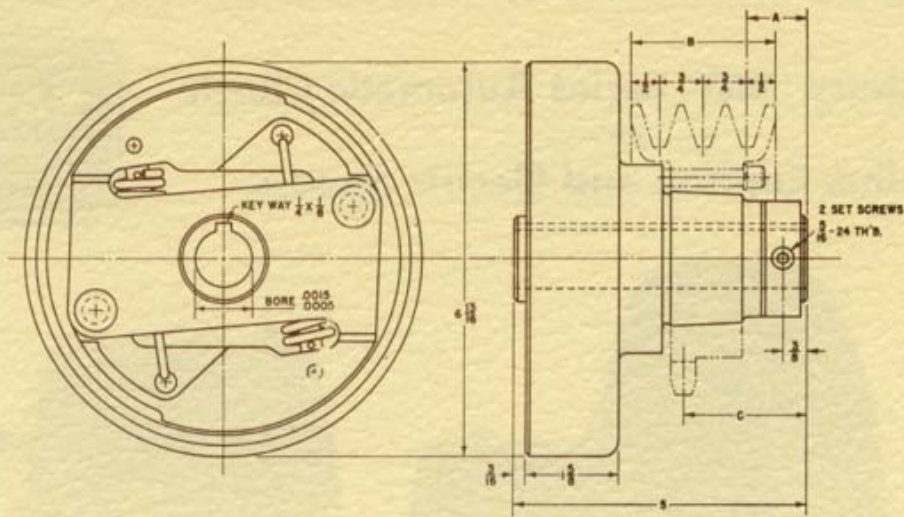

CLUTCH SELECTION CHART

CATALOG NUMBER	BORE	RELEASE RPM	SHEAVE OR SPROCKET	SHIPPING WEIGHT	USED ON
G-600-16	1"	1600	See Chart Below	8.6 lbs.	See engine selection chart
G-600-18	1 1/8"	1200	See Chart Below	8.5 lbs.	See engine selection chart
E-600-16	1"	—	See Chart Below	8.6 lbs.	2-3 HP, 1750 RPM Elec. Mtr.
E-600-18	1 1/8"	—	See Chart Below	8.5 lbs.	5 HP, 1750 RPM Elec. Mtr.

AVAILABLE SHEAVES AND SPROCKETS

The Salsbury "600" Series is designed to accommodate sheaves and sprockets to fit Fort Worth Steel & Machinery Company's "QDY" hub. The sizes below are available from Salsbury stock in Los Angeles, and from distributors of Fort Worth Steel & Machinery Company products in all principal cities in the U.S.A., or other manufacturers who supply sheaves or sprockets to fit the "QDY" hub.

SHEAVE DATA

O.D.	P.D.		2 GROOVE			3 GROOVE		
	A BELTS	B BELTS	DIM. A	DIM. B	WT. LBS.	DIM. A	DIM. B	WT. LBS.
4.95	4.2	4.6	1 3/8"	1 3/4"	4	1"	2 1/2"	5
5.15	4.4	4.8	"	"	4	"	"	6
5.35	4.6	5.0	"	"	5	"	"	6
5.55	4.8	5.2	"	"	5	"	"	6
5.75	5.0	5.4	"	"	6	"	"	7
5.95	5.2	5.6	"	"	6	"	"	7
6.15	5.4	5.8	"	"	6	"	"	8
6.35	5.6	6.0	"	"	6	"	"	8
6.55	5.8	6.2	"	"	7	"	"	9
6.75	6.0	6.4	"	"	7	"	"	9
6.95	6.2	6.6	"	"	7	"	"	9
7.15	6.4	6.8	"	"	7	"	"	10

SPROCKET DATA

PITCH	NO. TEETH	DIM. C	WT. LBS.	
3/4" Pitch A.S.A. No. 50 Tooth Thickness .343"	21	2-1/8"	2.5	
	22	"	2.7	
	23	"	2.8	
	24	"	2.9	
	25	"	3.0	
	26	"	3.2	
1/2" Pitch A.S.A. No. 60 Tooth Thickness .459"	28	"	3.5	
	30	"	2.0	
	1" Pitch A.S.A. No. 80 Tooth Thickness .575"	18	2-3/32"	3.5
		19	"	3.8
		20	"	3.9
		21	"	4.2
22		"	4.5	
23		"	4.8	
1 1/4" Pitch A.S.A. No. 100 Tooth Thickness .692"	24	"	5.0	
	15	2-1/32"	4.5	
	16	"	6.0	
	17	"	6.5	
	18	"	7.0	
	19	"	7.5	
1 1/2" Pitch A.S.A. No. 100 Tooth Thickness .692"	12	1-31/32"	4.6	
	13	"	5.5	
	14	"	7.7	

TO MOUNT SHEAVE OR SPROCKET

IMPORTANT—Be sure tapered cone surface of clutch hub and inside of sheave or sprocket hub are free of all foreign substances such as paint, grease or dirt. Wipe surfaces with a clean cloth moistened with a light grade of machine oil (about SAE 20). This will permit a more uniform draw and prevent cone surfaces from freezing before being properly tightened.

- Slide large end of sheave or sprocket taper bore over cone, aligning pull-up bolt holes with tapped holes in flange of clutch hub. Assemble pull-up bolts and lock washers.
- Tighten pull-up bolts **ALTERNATELY** and **EVENLY**. Do not use extensions on wrench handles. There should be a gap between the face of the sheave or sprocket hub and the flange of the clutch hub to insure a satisfactory cone grip and press fit. **CAUTION: THIS GAP MUST NOT BE CLOSED.**

TO DEMOUNT SHEAVE OR SPROCKET

- Loosen set screw in clutch hub and slide complete assembly from engine or motor shaft. If force is required, apply pressure to end of clutch hub only. **DO NOT USE PULLER ATTACHED TO SHEAVE, SPROCKET OR CLUTCH HOUSING.**
- Remove pull-up bolts and screw two of them into threaded holes in sheave or sprocket and against flange of clutch hub. To break loose, tap end of clutch hub lightly with a soft headed mallet while maintaining back-off bolt pressure.

SALSBU

POWER TRANSMISSION
 DIVISION OF
SALSBU CORPORATION

1161 EAST FLORENCE AVENUE

LOS ANGELES I, CALIFORNIA

Telephone Jefferson 4151

February 1, 1954

GASOLINE ENGINE SELECTION CHART

600 SERIES AUTOMATIC CLUTCH

The Salsbury 600 Series Automatic Clutches are designed to operate on the following popular make gasoline engines within the speed range indicated. In each case the minimum and maximum operating speeds shown are within the operating speed range recommended by the engine manufacturer. To insure a long life of satisfactory service from both engine and clutch, drive should be designed for engine speeds within this range.

Release springs are provided in the clutch to insure load-free idling of the engine at or below the indicated maximum idling RPM.

The 600 Series will operate on other make engines not shown, provided their characteristics are comparable.

Clutch Catalog Number	Maximum Idling RPM	Engine Make	Engine Model	Minimum Operating RPM	Maximum Operating RPM
G600-16	1500	Briggs & Stratton	14	2200	3200
		Briggs & Stratton	23	2200	3200
		Gladden	75	1800	3400
		Kohler	K160	1800	3600
		Lauson	P-25	1300	3600
		Lauson	PAC	1800	3000
		Wisconsin	AA-AB-AK	1800	2600
Wisconsin	ABN	1800	3600		
Wisconsin	AKN	1800	3600		
G600-18	1100	Wisconsin	AEN	1800	3600
		Wisconsin	AEH	1800	3200

SALSBURY
AUTOMATIC CLUTCHES

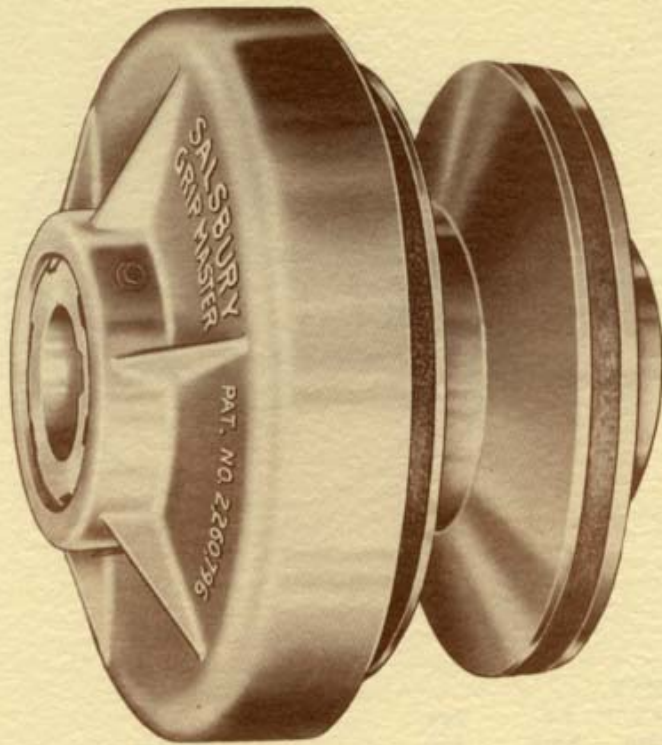

MODEL 5-A

Gripmaster Series

Automatic Clutch

**LOW Cost -- HIGH Quality
Rugged and Dependable**

— FOR —

Gasoline Engines or Electric Motors

★ SALSBUARY GRIPMASTER AUTOMATIC CLUTCHES are ideal for driven machinery and equipment where initial torque exceeds operating power requirement or momentary under or overloads transpire in the operation cycle.

★ *These clutches automatically engage, smoothly and positively, at pre-determined engine speed and disengage upon deceleration below that speed, thereby precluding stalling of engine. This flexibility of load pickup adds to both life and capacity of not only the engine but of the driven machine as well.*

★ The activating mechanism of the GRIPMASTER AUTOMATIC CLUTCH is far more simple than a manually operated lever or pedal. A set of steel balls enclosed in a garter spring are thrown out by centrifugal force. As they travel up the ramp, pressure is exerted against the facings causing them to grip the pulley and quickly lock it together as a single unit to deliver full engine horsepower to the load.

★ *Molded lining on the facing plates provide longer life and more dependable service. Clutch facings may be replaced quickly without riveting or removing clutch from engine crankshaft.*

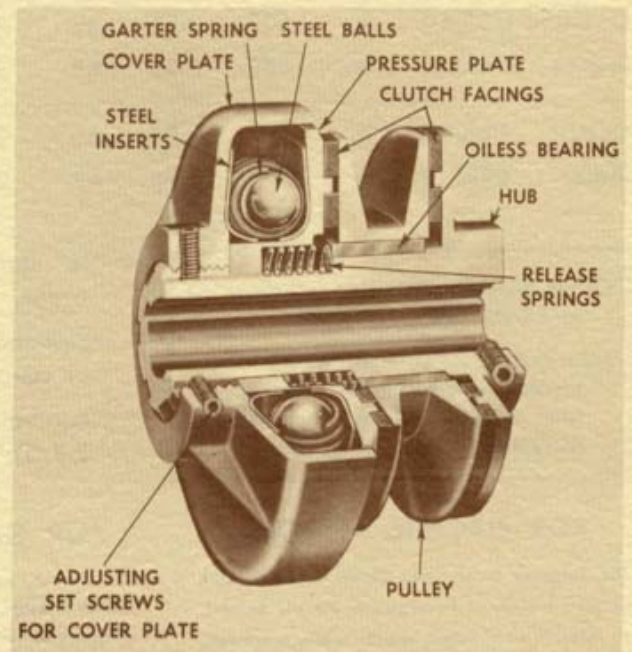

OUTSTANDING FEATURES

1. Simple but sturdy construction—few parts.
2. Small in size, light in weight.
3. Can be installed without altering present shaft extension.
4. Simple adjustments without removing clutch from engine.
5. Performance proved by years of dependable service on wide variety of applications.
6. Highly recommended by users.
7. Approved by engine manufacturers.
8. Operates efficiently in either direction.

POWER TRANSMISSION DIVISION

1161 EAST FLORENCE • LOS ANGELES 1, CALIFORNIA • PHONE JEFFERSON 4151

SALSBURY
CORPORATION

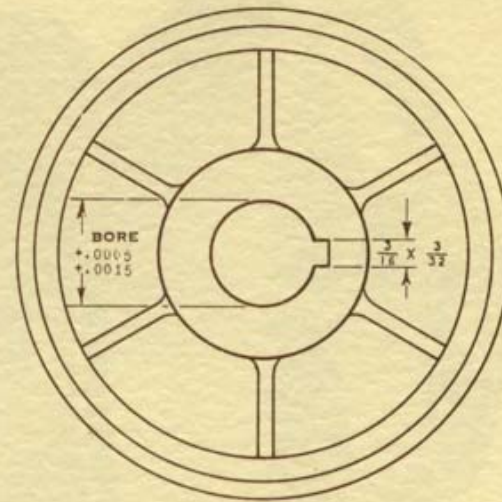
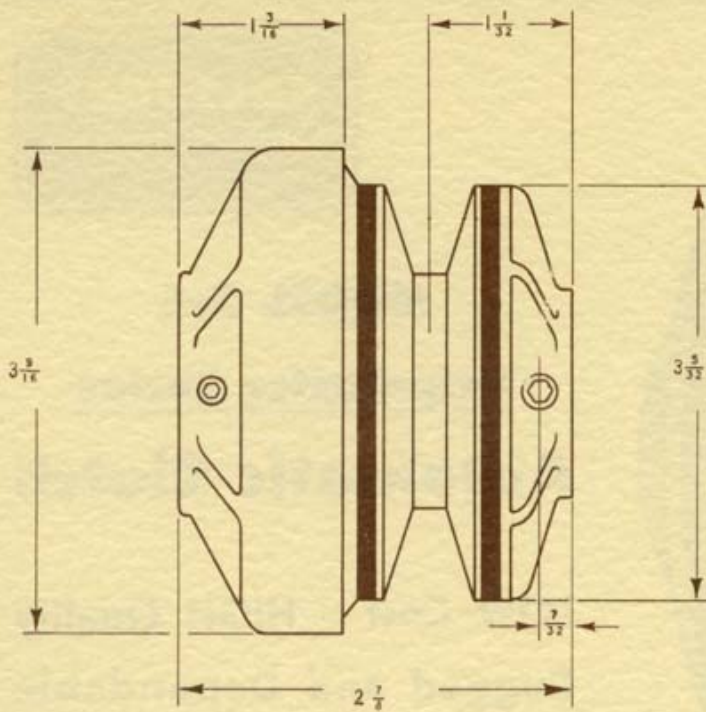

**Pulley Dimensions

Cat. No.	Bore *	Release RPM	**Pulley Dimensions		P.D.*** A Belt	P.D. B Belt	Shpg. Wgt.	USED ON	
			O.D.	Grv.					
Gasoline Engine	G5A-10	5/8	1500	2.95	AB	2.2	2.6	2 lbs.	See Engine Selection Chart
Gasoline Engine	G5A-12	3/4	1500	2.95	AB	2.2	2.6	2 lbs.	See Engine Selection Chart
Electric Motor	E5A-10	5/8		2.95	AB	2.2	2.6	2 lbs.	1/4-1/2 HP-1750 rpm Elec. Mtrs.
Electric Motor	E5A-12	3/4		2.95	AB	2.2	2.6	2 lbs.	1/2-3/4 HP-1750 rpm Elec. Mtrs.

Other Salsbury models ranging up to 15 HP are available.

Also available are Salsbury Automatic Transmissions in many custom built designs for specific purposes.

FOR ELECTRIC MOTORS

The Salsbury Gripmaster Clutch automatically permits fractional horsepower electric motors to operate at efficient speeds while accelerating the load. The Gripmaster reduces starting current demand as well as provides positive protection to the motor from damage due to low voltage conditions. By the same token, the Gripmaster provides overload protection.

Submit your clutch problem to the Power Transmission Division, Salsbury Corporation. . . Of course, no obligation will be implied.

*1/2" Bore available on special order.

**Optional Pulley sizes available on special order.

***Equivalent O.D. for A Belt is 2-7/16".

FOR GASOLINE ENGINES

The latest model of Salsbury Gripmaster Clutch is ideal for gasoline engines from three quarters to four horsepower. It automatically picks up the load smoothly but positively by merely accelerating the engine from idling to operating speed. The Gripmaster absolutely protects the engine and driven mechanism from damage due to excessive or sudden overloads.

TYPICAL APPLICATIONS

Agricultural Equipment
Air Compressors
Amusement Park Rides
Concrete Buggies
Concrete Smoothers
Concrete Vibrators
Delivery Trucks
Garden Cultivators
Garden Tractors
Industrial Trucks
Lawn Mowers
Lawn Renovators
Motor Bikes
Motorcycles
Motor Scooters
Portable Conveyors
Portable Pumps
Posthole Diggers
Refrigerator Compressors
Sand Spreaders
Ski-tows
Snow Buggies
Truck Refrigerators

RECEIVED

MAR 5 1956

F. K. WOLL



SALSBUURY CORPORATION

1161 EAST FLORENCE AVENUE • LOS ANGELES 1 • CALIFORNIA • Telephone LUdlow 7-4151

PRICE LIST

Effective:
December 1, 1955

5A GRIPMASTER SERIES CLUTCHES

<u>Model No.</u>	<u>List Price</u>
G5A-10 and G5A-12	\$ 11.00
E5A-10 and E5A-12	11.00
1024-15	11.00

6A GRIPMASTER SERIES CLUTCHES

1370-15	29.50
1371-15	30.50

TOG-O-LOC SERIES CLUTCHES

20B01-2	99.00
20B01-3	99.00
20B01-4	101.50
20B01-5	101.50
20B01-6	104.50
20B01-7	104.50
20B01-8	104.50
20B01-9	104.50

600 SERIES CLUTCHES

G600-16 and G600-18 (Clutch Only, Less Sheave or Sprocket)	43.45
E600-16 and E600-18 (Clutch Only, Less Sheave or Sprocket)	43.45

300 SERIES AUTOMATIC TRANSMISSIONS

Assembly Number	Engine Shaft Dia.	Release RPM	**Shaft Center Distance	Used On	*List Price
1377-12	5/8"	1200	6.44"	All Gasoline Engines 1 to	\$ 49.50
1377-17	5/8"	1700	6.44"	3 HP with 5/8" Dia. Shaft	49.50
549-12	3/4"	1200	6.44"	All Gasoline Engines 2 to	49.50
549-17	3/4"	1700	6.44"	4 HP with 3/4" Dia. Shaft	49.50

600 SERIES AUTOMATIC TRANSMISSIONS

583-12	1"	1200	8"		106.90
583-16	1"	1600	8"		106.90
1314-12	1"	1200	9.38"	All Gasoline Engines 4 to	108.40
1314-16	1"	1600	9.38"	6 HP with 1" Dia. Shaft	108.40
1044-12	1"	1200	10.38"		109.50
1044-16	1"	1600	10.38"		109.50
1872-12	1"	1200	8"	All Gasoline Engines 6 to	124.00
1872-16	1"	1600	8"	8-1/2 HP with 1" Dia. Shaft	124.00
1795-12	1"	1200	9.38"		125.30
1795-16	1"	1600	9.38"	***Wisconsin AEN	125.30
1873-12	1"	1200	10.38"	***Wisconsin AEH	126.50
1873-16	1"	1600	10.38"		126.50

* List price includes drive pulley with clutch, drive pulley to crankshaft adapter sleeve, clutch shaft key, drive pulley mounting screw with washers, driven pulley assembly and belt.

** Belts available from stock for shaft center distances shown. Other belt lengths available on special order.

*** These engines furnished with standard 1-1/8" Dia. shaft. Turn engine shaft to 1" Dia. or engines can be obtained from manufacturer with 1" Dia. shaft.

SALSURY CLUTCHES TRANSMISSIONS

SHEAVES FOR 600 SERIES CLUTCH

O.D.	P.D. A Belt	P.D. B Belt	2 Groove		3 Groove	
			Part No.	List Price	Part No.	List Price
4.95	4.2	4.6	QD2B4.6	\$ 8.10	QD3B4.6	\$ 10.55
5.15	4.4	4.8	QD2B4.8	8.45	QD3B4.8	10.90
5.35	4.6	5.0	QD2B5.0	8.80	QD3B5.0	11.25
5.55	4.8	5.2	QD2B5.2	9.10	QD3B5.2	11.80
5.75	5.0	5.4	QD2B5.4	9.55	QD3B5.4	12.25
5.95	5.2	5.6	QD2B5.6	9.90	QD3B5.6	12.80
6.15	5.4	5.8	QD2B5.8	10.45	QD3B5.8	13.25
6.35	5.6	6.0	QD2B6.0	10.90	QD3B6.0	13.90
6.55	5.8	6.2	QD2B6.2	11.45	QD3B6.2	14.35
6.75	6.0	6.4	QD2B6.4	11.90	QD3B6.4	15.00
6.95	6.2	6.6	QD2B6.6	12.45	QD3B6.6	15.60
7.15	6.4	6.8	QD2B6.8	12.90	QD3B6.8	16.25

SPROCKETS FOR 600 SERIES CLUTCH

5/8" Pitch For #50 Chain			3/4" Pitch For #60 Chain		
Part No.	No. Teeth	List Price	Part No.	No. Teeth	List Price
50Y21	21	\$11.00	60Y18	18	\$10.45
50Y22	22	11.45	60Y19	19	12.00
50Y23	23	13.40	60Y20	20	14.00
50Y24	24	14.00	60Y21	21	14.20
50Y25	25	14.55	60Y22	22	15.00
50Y26	26	15.10	60Y23	23	15.55
50Y28	28	15.30	60Y24	24	16.30
50Y30	30	15.45			
1" Pitch For #80 Chain			1-1/4" Pitch For #100 Chain		
80Y15	15	12.75	100Y12	12	16.40
80Y16	16	15.10	100Y13	13	19.30
80Y17	17	16.65	100Y14	14	22.20
80Y18	18	18.10			
80Y19	19	20.10			

All prices are list and are F.O.B. Los Angeles, California, and are subject to change without notice.

RECEIVED

MAR 5 1956

F. K. WOLL